

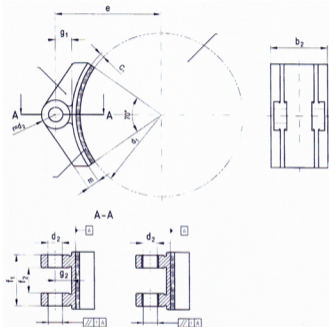

FRICTION TECHNOLOGY

ENGAGING CONTROL



d ₁	b ₂	c ₁	d ₂	e	f ₁	f ₂	g ₁	g ₂	m	zul. Form-Abw. n - p n' - p'	t	Gewicht [Kg]
			D10		0 -0,2	+0,2 0			max.			
200	70	8	20	140	65	35	32	24	17	0.15	0.1	0.5
250	90	8	25	170	80	40	37	29	22	0.15	0.1	0.8
315	110	10	30	212	100	50	44.5	34.5	25	0.15	0.15	1.4
400	140	10	35	260	125	63	50	40	30	0.2	0.15	2.1
500	180	12	40	320	160	80	58	46	33	0.2	0.15	3.9
630	225	12	45	390	200	100	63	51	36	0.3	0.2	5.7
710	255	15	50	440	224	112	70	56	40	0.3	0.2	8.6